



M-iQ

K-M54 SERIES

HOT WATER SANITIZING MULTIPLE-TANK RACK CONVEYOR WAREWASHERS

The clean solution

Special Features:

- **Industry-leading low water, energy and chemical consumption**
Consuming as little as 0.19 gallons (0.73 liters) per rack, the M-iQ K-M series is one of the most efficient rack conveyor dishwashers in the world. Advanced technologies further reduce energy and detergent use.
- **M-iQ Filter Technology**
Each tank features a multiple stage filtration process that first collects food soil, then flushes it out of the tank completely in high-pressure cycles. This improves performance, eases cleanup and reduces detergent consumption by up to 50%.
- **M-iQ Airflow Management**
M-iQ features an advanced, fully integrated airflow system that retains and redirects hot air within the machine. This improves heating efficiency and reduces exhaust emissions.
- **M-iQ Tank Management**
Each tank is equipped with an M-Filter system. Water levels are monitored and controlled intelligently and automatically. M-iQ automatically diverts water within the machine to maintain optimum level control and soil distribution.
- **M-iQ Washing Dynamics**
M-iQ employs a higher-pressure wash for improved soil removal and reduced water consumption. Water flow has been modeled using computational fluid dynamics. Water, energy and chemical consumption are all dramatically reduced.
- **M-iQ Energy Management**
M-iQ incorporates a 3-stage energy control system, as well as a variable-output booster heater, for optimal energy balance. The system dynamically adjusts to changes in heating distribution for minimal energy consumption.
- **M-iQ Control System**
M-iQ features a *CC Touch* glass touch screen with a high resolution color display. Screen information is customized based on the machine's operating mode for fast, intuitive operation. Kitchen management, dishroom staff and service personnel can quickly call up customized information, or save data to the controller's built-in memory.
- **M-iQ Intuitive Cleaning**
M-iQ features an automatic cleaning mode. Assisted by the soil removal capabilities of the M-Filter, this dramatically reduces cleanup time. Areas that require regular manual cleaning are marked in **blue** for less wasted effort by the staff.



Standard Features:

- Wash chamber with 3 HP (2.2 kW) pump motor
- Power rinse chamber with 1 HP (0.75 kW) pump motor
- Pumped final rinse with 3/4 HP (0.55 kW) pump motor
- Integral heated blower dryer with 2/3 HP (0.5 kW) motor
- Choice of prewash sections:
 - **K-M54 V6 N** P8:** 1' 11-5/8" (600mm) prewash with 1 HP (0.75 kW) pump, 208.8 racks/hr., 0.21 gals. (0.80 liters)/rack
 - **K-M54 V8 N** P8:** 2' 7-1/2" (800mm) prewash with 3 HP (2.2 kW) pump, 229.3 racks/hr., 0.19 gals. (0.73 liters)/rack
- 304-series stainless steel construction
- Fully automatic operation. Prewash, wash, power rinse and final rinse are activated only when ware is present
- Front-sloping tanks for complete drainage and easier cleaning. Automatic self-cleaning and drain feature is accessed from control panel to eliminate manual drain levers
- Double-wall insulated construction on front, top and back improves operator safety, conserves heating energy, and reduces noise and heat loss into the dishroom. Insulation is fully waterproofed to eliminate heavy doors and unsanitary waterlogging
- Standard lifting doors are full-width for each chamber, including the blower drying zone, for improved access
- Pumps are vertically-mounted to be self-draining and easily removed for servicing. Pumps include safety alert feature to inform the operator of a leaking pump seal

Optional Features:

- Direct drive sideloader
- 90° curved loader or unloader
- Combination 90° curved unloader/heated blower dryer
- Hinged doors
- Drain water tempering
- Flanged, bolt-down feet
- Single-point electrical connection (electrically-heated machines only; standard on steam-heated machines)

This dishwasher is compliant with the Reduction of Lead in Drinking Water Act (2011) amendment to the Safe Drinking Water Act (SDWA).



M-iQ Rack Conveyor - K-M54 Series - Electric heat, left to right

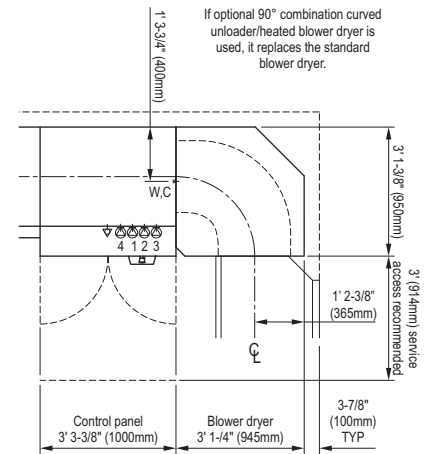
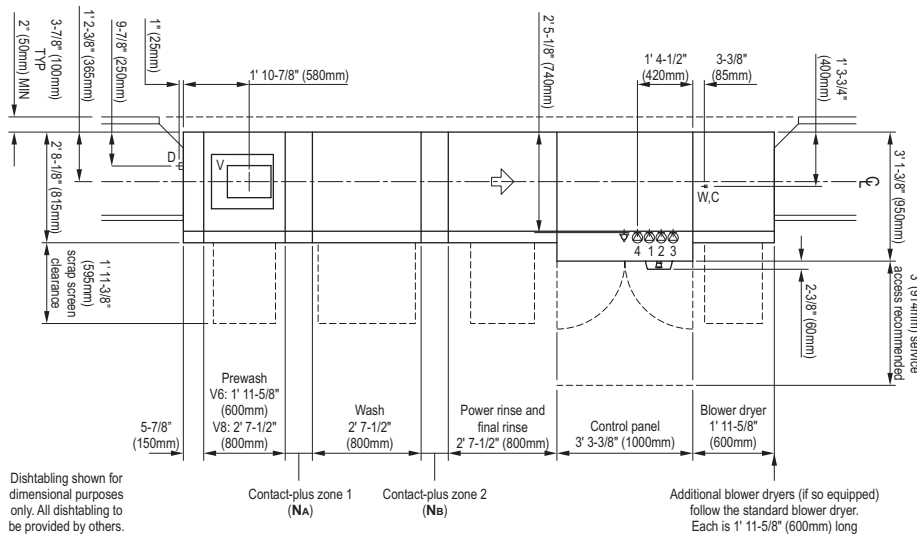
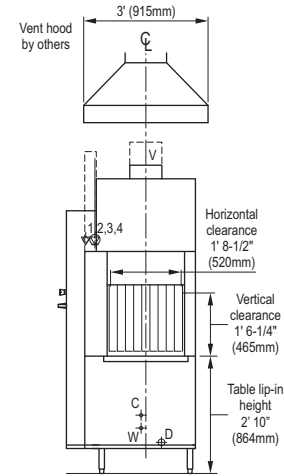
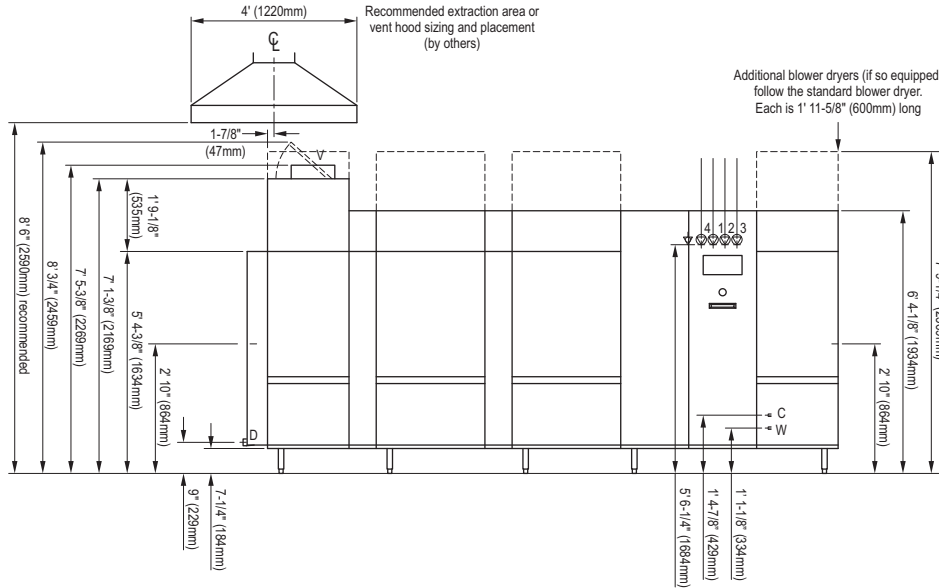

Dishabling shown for dimensional purposes only. All dishabling to be provided by others.

Contact-plus zone 1 (NA)
Contact-plus zone 2 (NB)

Additional blower dryers (if so equipped) follow the standard blower dryer. Each is 1' 11-5/8" (600mm) long

Contact-plus zone 1 (NA) Contact-plus zone 2 (NB) Model number code

None	7-7/8" (200mm)	K-M54 V? N02 P8
7-7/8" (200mm)	7-7/8" (200mm)	K-M54 V? N22 P8
11-7/8" (300mm)	11-7/8" (300mm)	K-M54 V? N33 P8
1' 3-3/4" (400mm)	1' 3-3/4" (400mm)	K-M54 V? N44 P8
1' 7-5/8" (500mm)	1' 7-5/8" (500mm)	K-M54 V? N55 P8
1' 11-5/8" (600mm)	1' 11-5/8" (600mm)	K-M54 V? N66 P8
2' 7-1/2" (800mm)	2' 7-1/2" (800mm)	K-M54 V? N88 P8
3' 3-3/8" (1000mm)	3' 3-3/8" (1000mm)	K-M54 V? N1010 P8

NOTE: As ware proceeds through the machine and closer to the final rinse, the water contacting the ware becomes warmer and cleaner. Large items and flat items (particularly sheet pans, trays, totes, etc.) can carry over cooler, soiled water forward in the machine. The contact-plus zone provides a landing area for this water, allowing it to return to the previous tank. This reduces detergent consumption and tank heating energy use.

Wider contact-plus zones also provide a surface that may be used to front-mount detergent or rinse aid systems.

Recommended contact-plus zone configurations:

- For machines washing plates/glasswares - **N02**
- For machines washing a typical ware mix - cafeteria trays and some sheet pans in addition to plates and glasswares - **N22**
- For machines washing containers - **N33** or larger, depending on the size of the container
- For machines with front-mounted detergent and rinse aid dispensers - **N33** or larger, depending on the size of the dispensing systems

Blower dryers

NOTE: All M-iQ rack conveyor warewashers feature at least one heated blower dryer section. One blower dryer provides good results for plates, cutlery and glassware in most cases.

For melamine ware or plastics (trays, insulated items, etc.) a second blower dryer is available, adding 1' 11-5/8" (600mm) to overall machine length.

For some special ware types, additional blower dryer zone(s) beyond the second may provide improved drying results. Consult MEIKO for assistance.

When installing the unit in a corner, a 90° combination curved unloader/heated blower dryer is available as an option. This option may not be combined with additional drying zones.

M-iQ Rack Conveyor - K-M54 Series - Electric heat, right to left

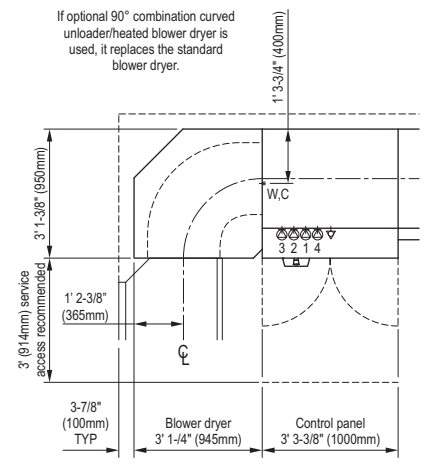
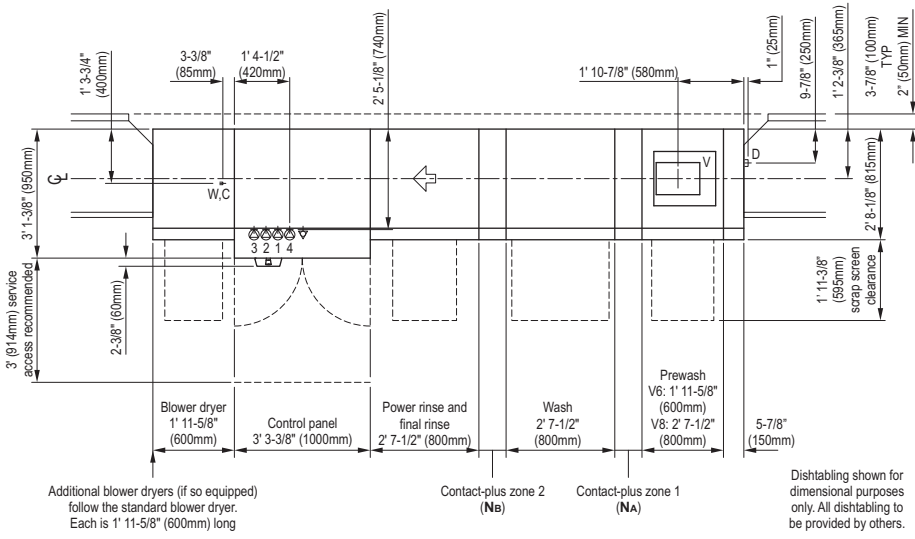
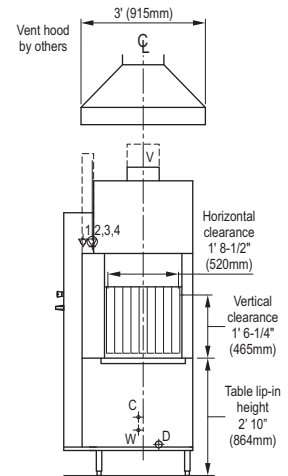
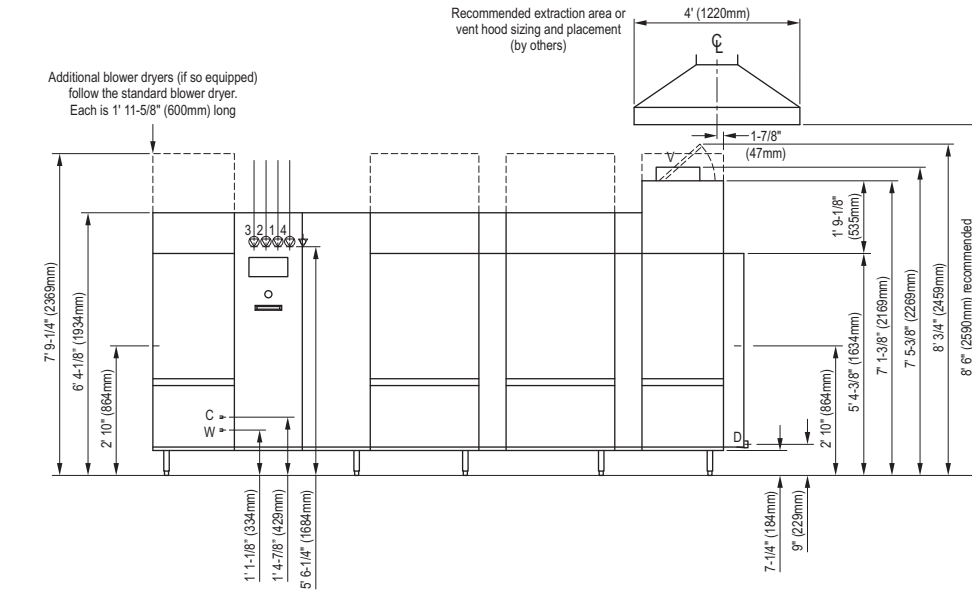

Contact-plus zone 1 (NA)	Contact-plus zone 2 (Nb)	Model number code
None	7-7/8" (200mm)	K-M54 V? N02 P8
7-7/8" (200mm)	7-7/8" (200mm)	K-M54 V? N22 P8
11-7/8" (300mm)	11-7/8" (300mm)	K-M54 V? N33 P8
1' 3-3/4" (400mm)	1' 3-3/4" (400mm)	K-M54 V? N44 P8
1' 7-5/8" (500mm)	1' 7-5/8" (500mm)	K-M54 V? N55 P8
1' 11-5/8" (600mm)	1' 11-5/8" (600mm)	K-M54 V? N66 P8
2' 7-1/2" (800mm)	2' 7-1/2" (800mm)	K-M54 V? N88 P8
3' 3-3/8" (1000mm)	3' 3-3/8" (1000mm)	K-M54 V? N1010 P8

NOTE: As ware proceeds through the machine and closer to the final rinse, the water contacting the ware becomes warmer and cleaner. Large items and flat items (particularly sheet pans, trays, totes, etc.) can carry over cooler, soiled water forward in the machine. The contact-plus zone provides a landing area for this water, allowing it to return to the previous tank. This reduces detergent consumption and tank heating energy use.

Wider contact-plus zones also provide a surface that may be used to front-mount detergent or rinse aid systems.

Recommended contact-plus zone configurations:

- For machines washing plates/glasswares - **N02**
- For machines washing a typical ware mix - cafeteria trays and some sheet pans in addition to plates and glasswares - **N22**
- For machines washing containers - **N33** or larger, depending on the size of the container
- For machines with front-mounted detergent and rinse aid dispensers - **N33** or larger, depending on the size of the dispensing systems

Blower dryers

NOTE: All M-iQ rack conveyor warewashers feature at least one heated blower dryer section. One blower dryer provides good results for plates, cutlery and glassware in most cases.

For melamine ware or plastics (trays, insulated items, etc.) a second blower dryer is available, adding 1' 11-5/8" (600mm) to overall machine length.

For some special ware types, additional blower dryer zone(s) beyond the second may provide improved drying results. Consult MEIKO for assistance.

When installing the unit in a corner, a 90° combination curved unloader/heated blower dryer is available as an option. This option may not be combined with additional drying zones.

M-iQ Rack Conveyor - K-M54 Series - Steam heat, left to right

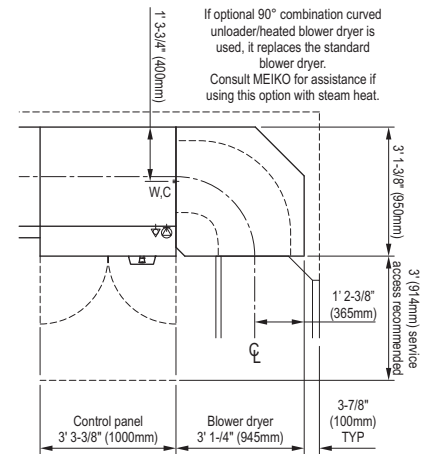
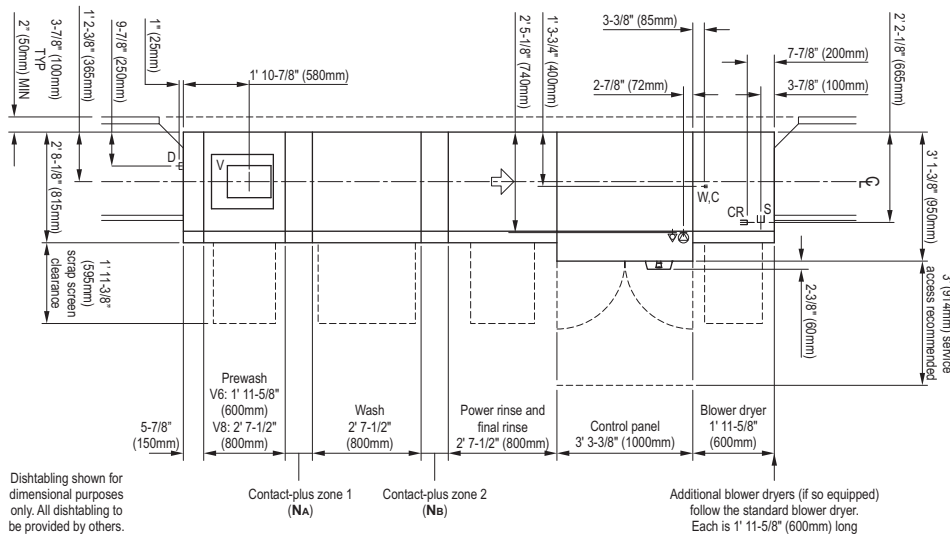
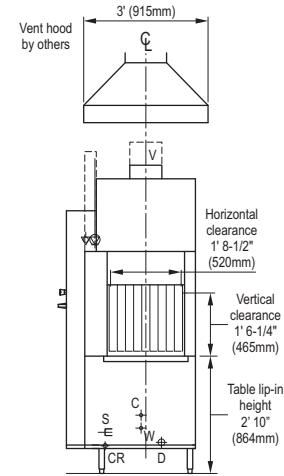
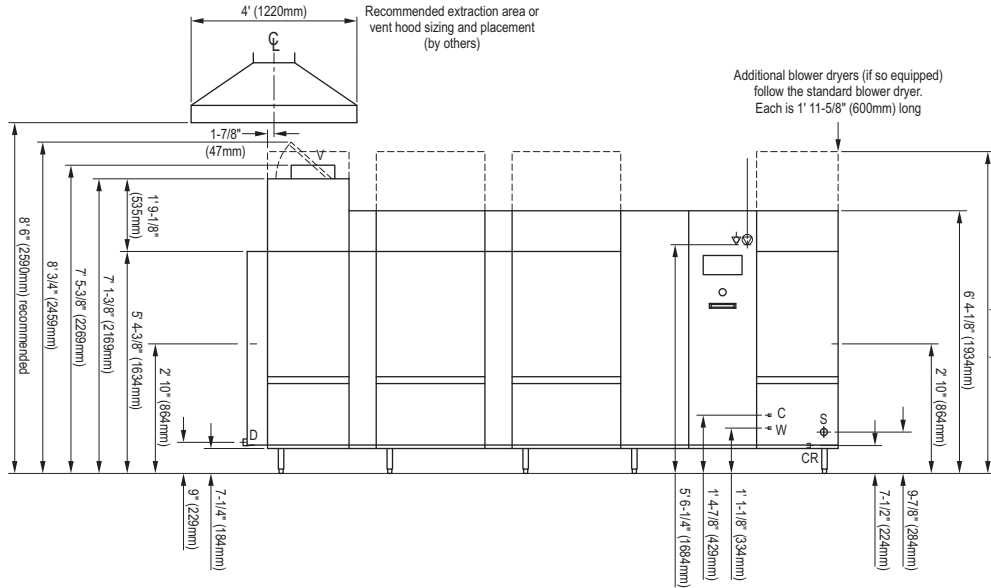

Dishabling shown for dimensional purposes only. All dishabling to be provided by others.

Contact-plus zone 1 (NA) Contact-plus zone 2 (NB) Model number code

None	7-7/8" (200mm)	K-M54 V? N02 P8
7-7/8" (200mm)	7-7/8" (200mm)	K-M54 V? N22 P8
11-7/8" (300mm)	11-7/8" (300mm)	K-M54 V? N33 P8
1' 3-3/4" (400mm)	1' 3-3/4" (400mm)	K-M54 V? N44 P8
1' 7-5/8" (500mm)	1' 7-5/8" (500mm)	K-M54 V? N55 P8
1' 11-5/8" (600mm)	1' 11-5/8" (600mm)	K-M54 V? N66 P8
2' 7-1/2" (800mm)	2' 7-1/2" (800mm)	K-M54 V? N88 P8
3' 3-3/8" (1000mm)	3' 3-3/8" (1000mm)	K-M54 V? N1010 P8

NOTE: As ware proceeds through the machine and closer to the final rinse, the water contacting the ware becomes warmer and cleaner. Large items and flat items (particularly sheet pans, trays, totes, etc.) can carry over cooler, soiled water forward in the machine. The contact-plus zone provides a landing area for this water, allowing it to return to the previous tank. This reduces detergent consumption and tank heating energy use.

Wider contact-plus zones also provide a surface that may be used to front-mount detergent or rinse aid systems.

Recommended contact-plus zone configurations:

- For machines washing plates/glasswares - **N02**
- For machines washing a typical ware mix - cafeteria trays and some sheet pans in addition to plates and glasswares - **N22**
- For machines washing containers - **N33** or larger, depending on the size of the container
- For machines with front-mounted detergent and rinse aid dispensers - **N33** or larger, depending on the size of the dispensing systems

Blower dryers

NOTE: All M-iQ rack conveyor warewashers feature at least one heated blower dryer section. One blower dryer provides good results for plates, cutlery and glassware in most cases.

For melamine ware or plastics (trays, insulated items, etc.) a second blower dryer is available, adding 1' 11-5/8" (600mm) to overall machine length.

For some special ware types, additional blower dryer zone(s) beyond the second may provide improved drying results. Consult MEIKO for assistance.

When installing the unit in a corner, a 90° combination curved unloader/heated blower dryer is available as an option. This option may not be combined with additional drying zones.

M-iQ Rack Conveyor - K-M54 Series - Steam heat, right to left

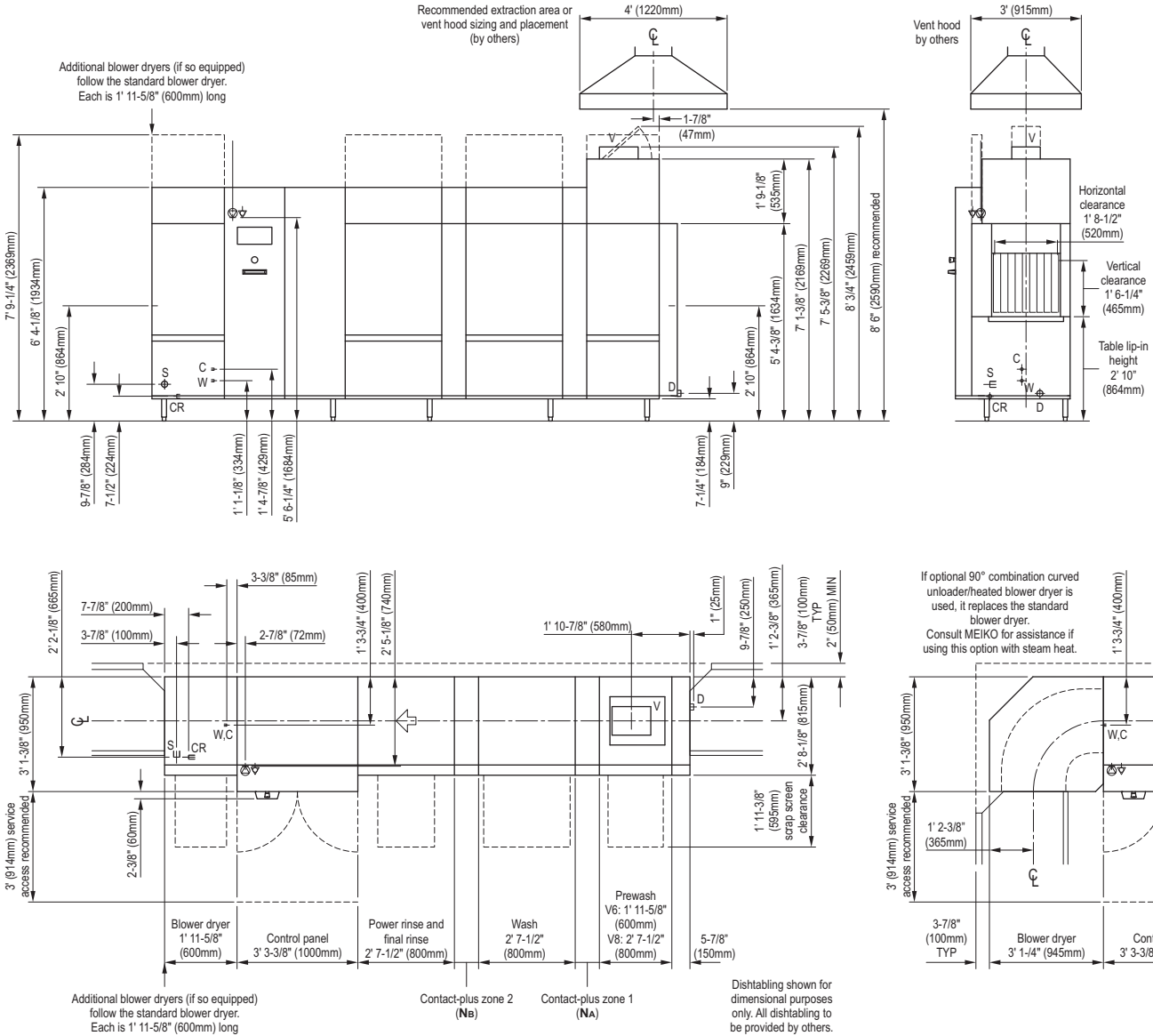

Contact-plus zone 1 (NA)	Contact-plus zone 2 (Nb)	Model number code
None	7-7/8" (200mm)	K-M54 V? N02 P8
7-7/8" (200mm)	7-7/8" (200mm)	K-M54 V? N22 P8
11-7/8" (300mm)	11-7/8" (300mm)	K-M54 V? N33 P8
1' 3-3/4" (400mm)	1' 3-3/4" (400mm)	K-M54 V? N44 P8
1' 7-5/8" (500mm)	1' 7-5/8" (500mm)	K-M54 V? N55 P8
1' 11-5/8" (600mm)	1' 11-5/8" (600mm)	K-M54 V? N66 P8
2' 7-1/2" (800mm)	2' 7-1/2" (800mm)	K-M54 V? N88 P8
3' 3-3/8" (1000mm)	3' 3-3/8" (1000mm)	K-M54 V? N1010 P8

NOTE: As ware proceeds through the machine and closer to the final rinse, the water contacting the ware becomes warmer and cleaner. Large items and flat items (particularly sheet pans, trays, totes, etc.) can carry over cooler, soiled water forward in the machine. The contact-plus zone provides a landing area for this water, allowing it to return to the previous tank. This reduces detergent consumption and tank heating energy use.

Wider contact-plus zones also provide a surface that may be used to front-mount detergent or rinse aid systems.

Recommended contact-plus zone configurations:

- For machines washing plates/glasswares - **N02**
- For machines washing a typical ware mix - cafeteria trays and some sheet pans in addition to plates and glasswares - **N22**
- For machines washing containers - **N33** or larger, depending on the size of the container
- For machines with front-mounted detergent and rinse aid dispensers - **N33** or larger, depending on the size of the dispensing systems

Blower dryers



NOTE: All M-iQ rack conveyor warewashers feature at least one heated blower dryer section. One blower dryer provides good results for plates, cutlery and glassware in most cases.

For melamine ware or plastics (trays, insulated items, etc.) a second blower dryer is available, adding 1' 11-5/8" (600mm) to overall machine length.

For some special ware types, additional blower dryer zone(s) beyond the second may provide improved drying results. Consult MEIKO for assistance.

When installing the unit in a corner, a 90° combination curved unloader/heated blower dryer is available as an option. This option may not be combined with additional drying zones.

M-iQ Rack Conveyor - K-M54 Series - Utility legend

-  Electrical connection(s)
- Electrically-heated machines have four (4) connections. Steam-heated machines have one (1) connection. Incoming leads must be appropriately sized for electrical supply. Individual circuit breaker/disconnects with lockout/tagout strongly recommended (provided by others).
 - Ampacity shown on utility chart, Page 7
-  Equipotential ground connection
- W** Water, warm (initial fill connection)
- Connection 1/2" NPT
 - Temperature 110-140°F (43-60°C). 140°F (60°C) recommended to reduce start-up time
 - Recommended water hardness 1-3 grains per U.S. gal.
 - Initial fill volume on utility chart, Page 7
- C** Water, cold (final rinse connection)
- Connection 1/2" NPT
 - Temperature cold as available. 50°F/10°C recommended to reduce steam emissions
 - Recommended water hardness 1-3 grains per U.S. gal.
 - Final rinse consumption on utility chart, Page 7
- D** Drain connection
- Connection to 2" (50mm) OD horizontal drain outlet (HDPE piping).
 - Indirect routing to 4" (100mm) floor drain recommended. Pipe to be connected to 2" (50mm) OD line (or 1-1/2" pipe) via no-hub. Additional piping to drain to be supplied by others.
- S** Steam connection (steam-heated machines only)
- Connection 1-1/2" NPT
 - Constant steam pressure is REQUIRED (pressure to be specified at time of order). If pressure is below minimum shown, consult factory. If pressure is above maximum shown, use of a regulator is REQUIRED (supplied by others).
 - Pressure ranges (specify at time of order):
 - 7-14 PSI (0.51-1.0 bars)
 - 15-22 PSI (1.1-1.5 bars)
 - 23-29 PSI (1.6-2.0 bars)
 - Consumption on utility chart, Page 7
- CR** Condensate return connection (steam-heated machines only)
- Connection 1" NPT
 - Condensate return line must be pressure-free
- V** Vent connection
- Machine vent is powered, intended for indirect vent connection
 - Extraction area detailed on drawings (pages 2-5) and utility chart (page 7)
 - Exhaust air volume on utility chart (page 7)

M-iQ Rack Conveyor - K-M54 Series - Suggested dishtabling

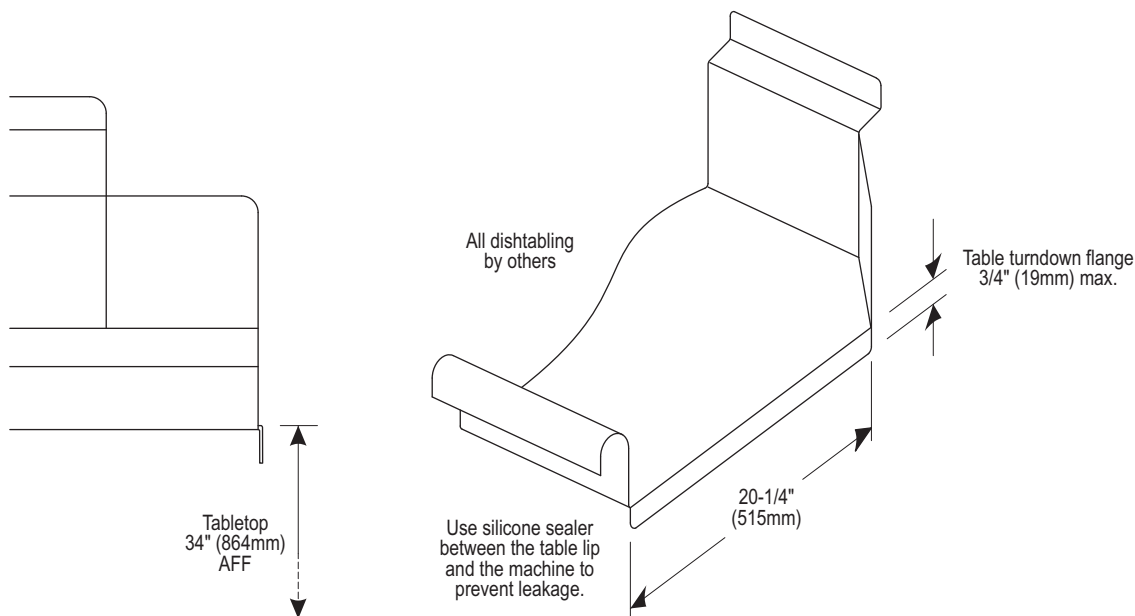

M-iQ Rack Conveyor - K-M54 Series - Technical Specifications

Operating Capacities and Conveyor Specifications (NSF Rated)

	K-M54 V6 N** P8	K-M54 V8 N** P8
Conveyor belt speed (max.)	5.80' (1.77m)/min.	6.37' (1.94m)/min.
Racks per hour (max)	208.8	229.3
Dishes per hour (max.) ¹	5,220	5,732
Water consumption/rack (max)	0.21 gal. (0.80 liters)	0.19 gal. (0.73 liters)
Water consumption/hr. (max)	44.0 gal. (166.6 liters)	44.0 gal. (166.6 liters)
Horizontal clearance	1' 8-1/2" (520mm)	1' 8-1/2" (520mm)
Vertical clearance	1' 6-1/4" (465mm)	1' 6-1/4" (465mm)

¹ Maximum dishes per hour as calculated with NSF formula (maximum racks per hour x 25). This formula assumes full machine utilization regardless of conveyor speed or ware size. Loading under operating conditions will vary. For assistance with ware throughput calculations and machine selection, contact MEIKO at sales@meiko.us.

² Heat load shown is for dishwasher only and does not include heat emitted by ware exiting the machine. Heat emitted by ware is site-specific and outside the scope of this spec sheet. For assistance, contact MEIKO at sales@meiko.us.

Venting Specifications

Machine exhaust	155 CFM (263m ³ /h)
Recommended room air	345 CFM (586m ³ /h)
Recommended total	500 CFM (850m ³ /h)
Recommended extraction area	3' (900mm) W x 4' (1220mm) L

Machine heat load ²	Sensible	Latent	Total
@ 208V/60Hz/3Ph	17,402 BTU/hr (5.1 kW)	8,872 BTU/hr (2.6 kW)	26,273 BTU/hr (7.7 kW)
Per add'l blwr dryer	+ 1,024 BTU (0.3 kW)	+ 341 BTU (0.1 kW)	+ 1,365 BTU (0.4 kW)
@ 230V/60Hz/3Ph	17,743 BTU/hr (5.2 kW)	8,872 BTU/hr (2.6 kW)	26,615 BTU/hr (7.8 kW)
Per add'l blwr dryer	+ 1,024 BTU (0.3 kW)	+ 682 BTU (0.2 kW)	+ 1,706 BTU (0.5 kW)
@ 460V/60Hz/3Ph	18,426 BTU/hr (5.4 kW)	9,213 BTU/hr (2.7 kW)	27,638 BTU/hr (8.1 kW)
Per add'l blwr dryer	+ 1,365 BTU (0.4 kW)	+ 1,024 BTU (0.3 kW)	+ 2,389 BTU (0.7 kW)

Water and Drain Specifications

Minimum water temperatures:

- Prewash tank No minimum - 110-140°F (43-60°C) typical
- Wash tank 150°F (66°C)
- Power rinse 160°F (72°C)
- Final rinse 180°F (82°C)

Incoming water temperatures:

- Initial fill line 110°-140°F (43°-60°C)
- Final rinse line Cold as available, 50°F (10°C) recommended

Incoming water line sizes:

- Initial fill line 1/2" NPT
- Final rinse line 1/2" NPT

	K-M54 V6 N** P8	K-M54 V8 N** P8
Initial fill	54.4 gal. (206.0 liters)	61.3 gal. (232.0 liters)
Consumption at 100% cap.	44.0 gal. (166.6 liters)/hr 0.21 gal. (0.80 liters)/rack	44.0 gal. (166.6 liters)/hr 0.19 gal. (0.73 liters)/rack
Recommended water hardness	1-3 grains/gal	

Drain specifications:

- Connection (standard) 2" (50mm) OD
- Connection (with no-hub) 1-1/2" pipe
- Recommended floor drain (min.) 4" (100mm)
- Maximum drain flow rate 15 gals. (56.8 liters) per minute

Machine Electrical Specifications

	208 V/60 Hz/3 Ph				230 V/60 Hz/3 Ph				460 V/60 Hz/3 Ph			
	TB1	TB2	TB3	TB4	TB1	TB2	TB3	TB4	TB1	TB2	TB3	TB4
Electric tank heat, K-M54 V6 N** P8	28.05 A	91.51 A	9.00 A	43.90 A	27.95 A	87.38 A	7.50 A	38.00 A	19.73 A	43.50 A	5.00 A	19.80 A
Electric tank heat, K-M54 V8 N** P8	34.15 A	91.51 A	9.00 A	43.90 A	34.05 A	87.38 A	7.50 A	38.00 A	22.88 A	43.50 A	5.00 A	19.80 A
Steam tank heat/elec. blower dryer, K-M54 V6 N** P8	44.01 A	--	--	--	41.49 A	--	--	--	27.01 A	--	--	--
Steam tank heat/steam blower dryer, K-M54 V6 N** P8	35.01 A	--	--	--	33.99 A	--	--	--	22.01 A	--	--	--
Steam tank heat/elec. blower dryer, K-M54 V8 N** P8	50.11 A	--	--	--	47.59 A	--	--	--	30.16 A	--	--	--
Steam tank heat/steam blower dryer, K-M54 V8 N** P8	41.11 A	--	--	--	40.09 A	--	--	--	25.16 A	--	--	--
Per additional elec. blower dryer section (electric machine)	+ 2.25 A	--	+9.00 A	--	+ 2.25 A	--	+ 7.50 A	--	+ 1.30 A	--	+ 5.00 A	--
Per additional elec. blower dryer section (steam machine)	+ 11.25 A	--	--	--	+ 9.75 A	--	--	--	+ 6.30 A	--	--	--
Per additional steam blower dryer section	+ 2.25 A	--	--	--	+ 2.25 A	--	--	--	+ 1.30 A	--	--	--

Component Electrical Specifications

Prewash pump motor, K-M54 V6 N** P8	1.00 hp (0.75 kW)
Prewash pump motor, K-M54 V8 N** P8	3.00 hp (2.20 kW)
Wash pump motor	3.00 hp (2.20 kW)
Power rinse pump motor	1.00 hp (0.75 kW)
Final rinse pump motor	0.75 hp (0.55 kW)
Vent motor	0.17 hp (0.13 kW)
Drive motor	0.16 hp (0.12 kW)
Blower dryer motor (each)	0.67 hp (0.50 kW)
Loading deck flushing pump	0.134 hp (0.10 kW)
M-Filter pump, prewash	0.134 hp (0.10 kW)
M-Filter pump, wash	0.134 hp (0.10 kW)
M-Filter pump, power rinse	0.134 hp (0.10 kW)
Control system, 208V/60Hz/3Ph or 230V/60Hz/3Ph	0.48 kW
Control system, 460V/60Hz/3Ph	3.30 kW

Electric Heating Elements (electrically-heated units only)

	208 V/60 Hz/3 Ph	230 V/60 Hz/3 Ph	460 V/60 Hz/3 Ph
Wash tank heat	13.86 kW	15.52 kW	15.40 kW
Power rinse tank heat	19.12 kW	19.29 kW	19.20 kW
Booster heater (max.) ¹	15.80 kW	15.20 kW	15.80 kW
Blower dryer heat (each)	3.20 kW	3.00 kW	4.00 kW

¹ Maximum heater output shown. Incoming cold water is pre-heated by heat captured from machine exhaust air prior to being heated to sanitizing 180°F (82°C) by booster heater. Booster heater incorporates variable output and is automatically regulated to ensure proper final rinse temperature, regardless of incoming water temperature or machine operating status (startup, operation, idle).

Typical booster output at operating temperature: 5.500 kW

Steam Specifications (steam-heated units only)

Steam supply connection	1-1/2" NPT		
Condensate return connection	1" NPT		
Steam supply pressure (must be specified):			
7-14 PSI (0.51-1.0 bars)	15-22 PSI (1.1-1.5 bars)	23-29 PSI (1.6-2.0 bars)	

Steam consumption (max.):

- Machine with electric blower dryer 180 lbs/hr (52.13 kW)
- Machine with steam heated blower dryer 191 lbs/hr (55.31 kW)
- Per additional steam blower dryer section + 11 lbs/hr (3.20 kW)

Note: All specifications are subject to change without notice based on MEIKO's dedicated product improvement program.

Equipment Specification: M-iQ K-M54 V ___ N ___ P8 - Item No. _____

Unit will be a:

___ **MEIKO M-iQ K-M54 V6 N ___ P8** multiple tank rack conveyor dishmachine, consisting of a 5-7/8" (150mm) entrance, 1' 11-5/8" (600mm) prewash compartment with 1 hp (0.75 kW) pump motor, 2' 7-1/2" (800mm) wash compartment with 3 hp (2.2 kW) pump motor, contact-plus zone between wash and rinse sections, 2' 7-1/2" (800mm) combination rinse compartment (with 1 hp /0.75 kW power rinse pump motor and 3/4 hp / 0.55 kW final rinse pump motor), and a 5' 3" (1600mm) combination control panel / heated blower drying zone. Unit will be NSF rated at a maximum conveyor speed of 5.80' (1.77m) per minute (208.8 dishracks per hour). Final rinse water consumption will not exceed a maximum of 44.0 U.S. gal. (166.6 liters)/hour, or 0.21 gal. (0.80 liters)/rack.

___ **MEIKO M-iQ K-M54 V8 N ___ P8** multiple tank rack conveyor dishmachine, consisting of a 5-7/8" (150mm) entrance, 2' 7-1/2" (800mm) prewash compartment with 3 hp (2.2 kW) pump motor, 2' 7-1/2" (800mm) wash compartment with 3 hp (2.2 kW) pump motor, contact-plus zone between wash and rinse sections, 2' 7-1/2" (800mm) combination rinse compartment (with 1 hp /0.75 kW power rinse pump motor and 3/4 hp / 0.55 kW final rinse pump motor), and a 5' 3" (1600mm) combination control panel / heated blower drying zone. Unit will be NSF rated at a maximum conveyor speed of 6.37' (1.94m) per minute (229.3 dishracks per hour). Final rinse water consumption will not exceed a maximum of 44.0 U.S. gal. (166.6 liters)/hour, or 0.19 gal. (0.73 liters)/rack.

Unit will be NSF and ETL listed.

Unit will utilize an internal booster heater to maintain a minimum 180°F (82°C) minimum fresh water sanitizing rinse. Wash tank temperature will be automatically maintained at a minimum temperature of 150°F (66°C). Power rinse tank temperature will be automatically maintained at a minimum temperature of 160°F (72°C).

All tank, final rinse and blower dryer heating will be accomplished by:

___ Electric heaters ___ Steam coil heaters *

* *NOTE: Some steam-heated machine configurations use electrically-heated blower dryers. Consult MEIKO for additional information.*

If steam, specify pressure:

___ 7-14 PSI ___ 15-22 PSI ___ 23-29 PSI
(0.51-1.0 bars) (1.1-1.5 bars) (1.6-2.0 bars)

Operating voltage will be:

___ 208V/60Hz/3Ph ___ 230V/60Hz/3Ph ___ 460V/60 Hz/3 Ph

Direction of operation will be:

___ Left to right ___ Right to left

Unit will be equipped with the following blower dryer system:

___ A single heated blower dryer for complete drying of all dishes, crockery and silverware, with a 0.67 hp blower dryer motor. Drying tunnel will be 1' 11-5/8" (600mm) in length.

___ Dual adjacent heated blower dryers for complete drying of all dishes, crockery and silverware, and improved drying of plastic trays. Each drying tunnel will feature a 0.67 hp blower dryer motor and will be 1' 11-5/8" (600mm) in length.

___ A 90° curved unloader with integral single heated blower dryer for complete drying of all dishes, crockery and silverware, with a 0.67 hp blower dryer motor. Drying tunnel adds 3' 1-1/4" (945mm) to machine length. Due to racks exiting front of machine, blower dryer access door is not present with this configuration.

Unit will feature a glass touch screen control panel and display. Display will provide customized information based on the machine operating mode, including tank and final rinse temperatures and selection of three different operating speeds. Display will provide service diagnostic information, automatic logging of operating history, and the ability for the operator to enter manual log entries for later retrieval.

Unit will feature a single-point drain connection and single-point indirect ventilation connections. Steam-heated machines will feature a single-point electrical connection.

Unit will have the following standard features:

Operating Features

Unit will feature fully automatic operation. Racks pushed into the machine will activate water flow and pump operation. Final rinse activates only when ware is located in the machine to conserve water, chemicals and heating energy. Pumped final rinse provides consistent results and water consumption regardless of variations in supply water pressure. Waste Air Heat Recovery System reclaims waste heat generated by the machine as free energy to preheat the incoming rinse water, reducing energy consumption and allowing hot-water sanitizing from a cold water supply (minimum 50°F / 10°C). Water will be delivered from Waste Air Heat Recovery System exchanger to an internal booster heater to provide the required rise for a minimum 180°F (82°C) sanitizing final rinse. Booster heater will incorporate variable output and will be automatically regulated to ensure optimum performance regardless of incoming water temperature or machine operating status (startup, operation, idle).

Unit will feature fully automatic operation with one-touch selection of three different conveyor speeds. Unit will feature a main control panel on the front of the machine as well as a push-pull emergency stop switch. Main control panel will be a glass touch screen display providing access to temperature displays, machine status, service diagnostics and machine logs as well as operating controls. Display will be capable of displaying information in multiple selectable languages to include English, French, Spanish and German.

Construction Features

Clearance height within the machine will be 1' 6-1/4" (465mm). Rack entrance height will be 2' 10" (864mm) A.F.F., +/- 1/2" (12mm) from adjustable legs, to ensure compatibility with standard dishtabling. Rack drive will pull racks smoothly from either side, rather than using a center-drive configuration, to prevent obstruction of the spray from lower wash and rinse arms.

Unit will feature double-wall, insulated stainless steel construction on front, top and rear panels to retain heat inside the machine, conserve energy and provide a cool-to-the-touch exterior. Prewash, wash and power rinse manifolds will be internally mounted to ensure a cool-to-the-touch rear panel, and will be spaced from rear wall of tank for easier cleaning.

Tank drains will feature magnetic switches to prevent operation if drain plug is not in place. Tank pump motors will be vertically-installed for easier serviceability and self-draining. Motors will include a safety switch to automatically signal the operator if a leaking pump seal is detected.

Wash arms of unit will be mounted in easily-removed assemblies, and will feature concave, slotted nozzles to minimize clogging. All prewash, wash, power rinse and final rinse arms will be of stainless steel construction. Final rinse nozzles to feature individual, screw-in stainless steel orifices for durability and simple cleaning. Front-sloping wash tanks will be of all 304-series stainless steel construction.

Cleaning Features

Prewash, wash and power rinse tanks will each feature a multi-stage filtration system with multiple, nesting scrap screens. Food soil will be collected and sorted by nested scrap screens and flushed into the drain line using a dedicated 0.134 hp M-Filter active filtration pump. Active M-iQ filtration will completely eliminate the need to manually remove and empty scrap baskets during operation. Upon shutdown, unit will use water already inside the machine, as well as a minimal amount of fresh water, for an automatic cleaning mode to reduce the need for manual cleaning. All components of unit that require regular manual cleaning will be marked in a blue accent color for easy identification. Prewash, wash and power rinse arm end caps will be tethered to arms with braided stainless steel wire to prevent loss during cleaning.

Efficiency Features

Unit will feature a single-point vent connection. Heat will be drawn the length of the machine to the load end vent for superior temperature distribution, reduced air emissions and reduced energy consumption. Load end vent will incorporate a MEIKO Waste Air Heat Recovery System heat exchanger to preheat incoming final rinse water and cool exhaust air, permitting final rinse operation using a cold water supply. Unit will employ active soil filtration and removal in each tank to reduce detergent consumption by up to 50%.

Unit will have the following optional features:

- ___ Direct drive sideloader
- ___ 90° curved loader
- ___ 90° curved unloader
- ___ Drain water tempering - reduces drain water below 140°F (60°C)
- ___ Single-point electrical connection (electrically-heated machines only)
- ___ Flanged, bolt-down feet

Unit will include the following doors:

- ___ Spring-loaded lifting doors extending the full width of each applicable section (prewash, wash, rinse, blower dryer). All doors will feature dual-wall, insulated construction, and door safety switches to prevent operation while in the open position.
- ___ Hinged doors extending the full width of each applicable section (prewash, wash, rinse, blower dryer). All doors will feature dual-wall, insulated construction, and door safety switches to prevent operation while in the open position. Tanks and sections 2' (600mm) in length or shorter will feature a single door. Longer tanks and sections will feature dual doors.

Unit will have the following contact-plus zones:

Contact-plus zones between prewash and wash sections (optional) and between wash and rinse sections (standard) minimize cool/soiled water carryover between tanks, which reduces heating energy and detergent consumption.

Between prewash and wash sections (first digit after "N" in model number)

- ___ 0: None (standard) ___ 2: 7-7/8" (200mm) ___ 3: 11-7/8" (300mm)
- ___ 4: 15-3/4" (400mm) ___ 5: 19-5/8" (500mm) ___ 6: 23-5/8" (600mm)
- ___ 8: 31-1/2" (800mm) ___ 10: 39-3/8" (1000mm)

Between wash and rinse sections (second digit after "N" in model number)

- ___ 2: 7-7/8" (200mm, standard) ___ 3: 11-7/8" (300mm)
- ___ 4: 15-3/4" (400mm) ___ 5: 19-5/8" (500mm) ___ 6: 23-5/8" (600mm)
- ___ 8: 31-1/2" (800mm) ___ 10: 39-3/8" (1000mm)



M-iQ

K-L54 SERIES

HOT WATER SANITIZING MULTIPLE-TANK RACK CONVEYOR WAREWASHERS

The clean solution

Special Features:

- **Industry-leading low water, energy and chemical consumption**
Consuming only 0.15 gallons (0.57 liters) per rack, the M-iQ K-L series is one of the most efficient rack conveyor dishwashers in the world. Advanced technologies further reduce energy and detergent use.
- **M-iQ Filter Technology**
Each tank features a multiple stage filtration process that first collects food soil, then flushes it out of the tank completely in high-pressure cycles. This improves performance, eases cleanup and reduces detergent consumption by up to 50%.
- **M-iQ Airflow Management**
M-iQ features an advanced, fully integrated airflow system that retains and redirects hot air within the machine. This improves heating efficiency and reduces exhaust emissions.
- **M-iQ Tank Management**
Each tank is equipped with an M-Filter system. Water levels are monitored and controlled intelligently and automatically. M-iQ automatically diverts water within the machine to maintain optimum level control and soil distribution.
- **M-iQ Washing Dynamics**
M-iQ employs a higher-pressure wash for improved soil removal and reduced water consumption. Water flow has been modeled using computational fluid dynamics. Water, energy and chemical consumption are all dramatically reduced.
- **M-iQ Energy Management**
M-iQ incorporates a 3-stage energy control system, as well as a variable-output booster heater, for optimal energy balance. The system dynamically adjusts to changes in heating distribution for minimal energy consumption.
- **M-iQ Control System**
M-iQ features a *CC Touch* glass touch screen with a high resolution color display. Screen information is customized based on the machine's operating mode for fast, intuitive operation. Kitchen management, dishroom staff and service personnel can quickly call up customized information, or save data to the controller's built-in memory.
- **M-iQ Intuitive Cleaning**
M-iQ features an automatic cleaning mode. Assisted by the soil removal capabilities of the M-Filter, this dramatically reduces cleanup time. Areas that require regular manual cleaning are marked in **blue** for less wasted effort by the staff.



Standard Features:

- Two wash chambers, each with 3 HP (2.2 kW) pump motor
- Power rinse chamber with 1 HP (0.75 kW) pump motor
- Pumped final rinse with 3/4 HP (0.55 kW) pump motor
- Integral heated blower dryer with 2/3 HP (0.5 kW) motor
- Choice of prewash sections:
 - **K-L54 V6 N** P8:** 1' 11-5/8" (600mm) prewash with 1 HP (0.75 kW) pump, 297.7 racks/hr., 0.15 gals. (0.57 liters)/rack
 - **K-L54 V8 N** P8:** 2' 7-1/2" (800mm) prewash with 3 HP (2.2 kW) pump, 297.7 racks/hr., 0.15 gals. (0.57 liters)/rack
- 304-series stainless steel construction
- Fully automatic operation. Prewash, wash, power rinse and final rinse are activated only when ware is present
- Front-sloping tanks for complete drainage and easier cleaning. Automatic self-cleaning and drain feature is accessed from control panel to eliminate manual drain levers
- Double-wall insulated construction on front, top and back improves operator safety, conserves heating energy, and reduces noise and heat loss into the dishroom. Insulation is fully waterproofed to eliminate heavy doors and unsanitary waterlogging
- Standard lifting doors are full-width for each chamber, including the blower drying zone, for improved access
- Pumps are vertically-mounted to be self-draining and easily removed for servicing. Pumps include safety alert feature to inform the operator of a leaking pump seal

Optional Features:

- Direct drive sideloader
- 90° curved loader or unloader
- Combination 90° curved unloader/heated blower dryer
- Hinged doors
- Drain water tempering
- Flanged, bolt-down feet
- Single-point electrical connection (electrically-heated machines only; standard on steam-heated machines)

This dishwasher is compliant with the Reduction of Lead in Drinking Water Act (2011) amendment to the Safe Drinking Water Act (SDWA).



M-iQ Rack Conveyor - K-L54 Series - Electric heat, left to right

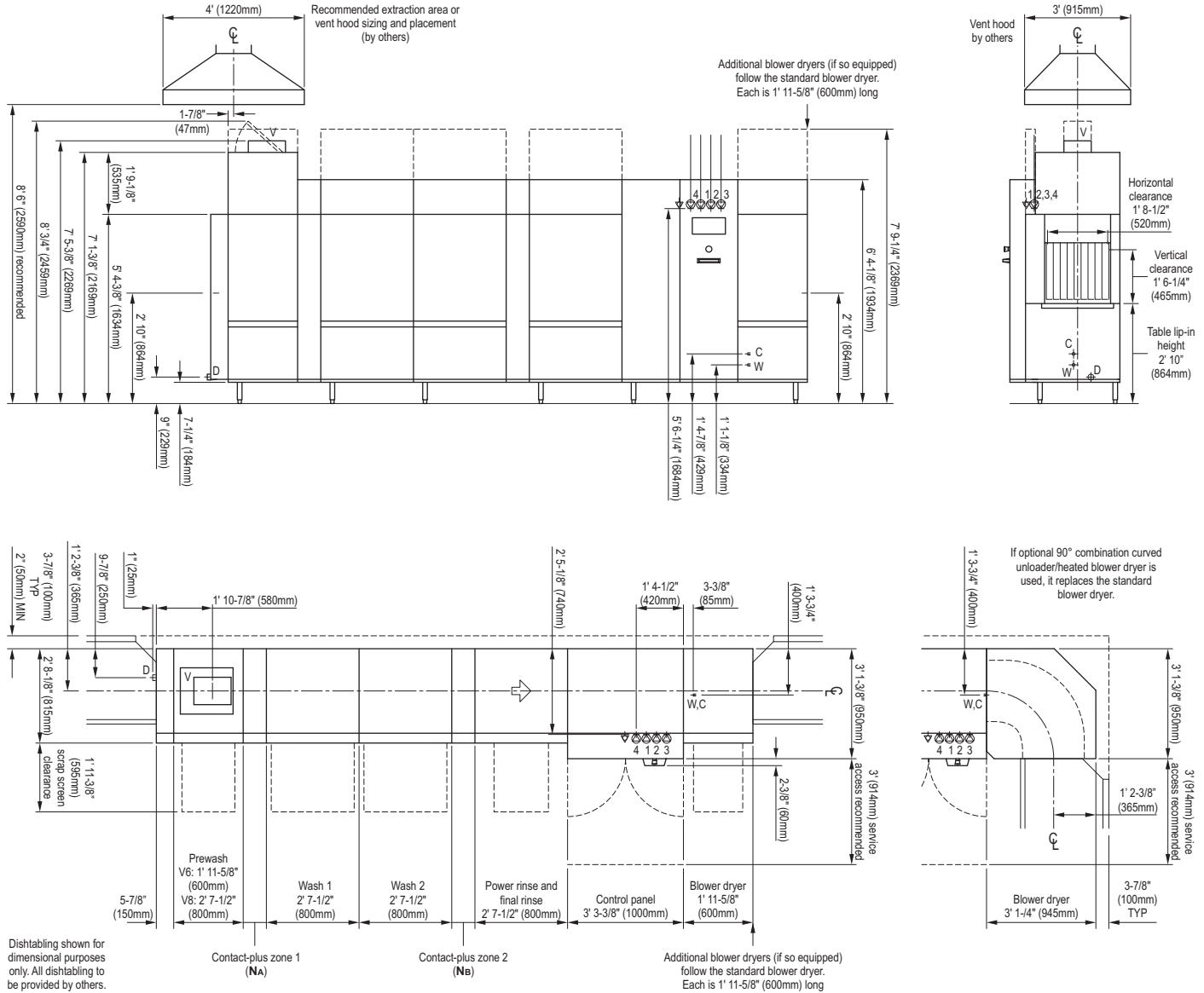

Contact-plus zone 1 (NA) Contact-plus zone 2 (Nb) Model number code

None	7-7/8" (200mm)	K-L54 V? N02 P8
7-7/8" (200mm)	7-7/8" (200mm)	K-L54 V? N22 P8
11-7/8" (300mm)	11-7/8" (300mm)	K-L54 V? N33 P8
1' 3-3/4" (400mm)	1' 3-3/4" (400mm)	K-L54 V? N44 P8
1' 7-5/8" (500mm)	1' 7-5/8" (500mm)	K-L54 V? N55 P8
1' 11-5/8" (600mm)	1' 11-5/8" (600mm)	K-L54 V? N66 P8
2' 7-1/2" (800mm)	2' 7-1/2" (800mm)	K-L54 V? N88 P8
3' 3-3/8" (1000mm)	3' 3-3/8" (1000mm)	K-L54 V? N1010 P8

NOTE: As ware proceeds through the machine and closer to the final rinse, the water contacting the ware becomes warmer and cleaner. Large items and flat items (particularly sheet pans, trays, totes, etc.) can carry over cooler, soiled water forward in the machine. The contact-plus zone provides a landing area for this water, allowing it to return to the previous tank. This reduces detergent consumption and tank heating energy use.

Wider contact-plus zones also provide a surface that may be used to front-mount detergent or rinse aid systems.

Recommended contact-plus zone configurations:

- For machines washing plates/glasswares - **N02**
- For machines washing a typical ware mix - cafeteria trays and some sheet pans in addition to plates and glasswares - **N22**
- For machines washing containers - **N33** or larger, depending on the size of the container
- For machines with front-mounted detergent and rinse aid dispensers - **N33** or larger, depending on the size of the dispensing systems

Blower dryers

NOTE: All M-iQ rack conveyor warewashers feature at least one heated blower dryer section. One blower dryer provides good results for plates, cutlery and glassware in most cases.

For melamine ware or plastics (trays, insulated items, etc.) a second blower dryer is available, adding 1' 11-5/8" (600mm) to overall machine length.

For some special ware types, additional blower dryer zone(s) beyond the second may provide improved drying results. Consult MEIKO for assistance.

When installing the unit in a corner, a 90° combination curved unloader/heated blower dryer is available as an option. This option may not be combined with additional drying zones.

M-iQ Rack Conveyor - K-L54 Series - Electric heat, right to left

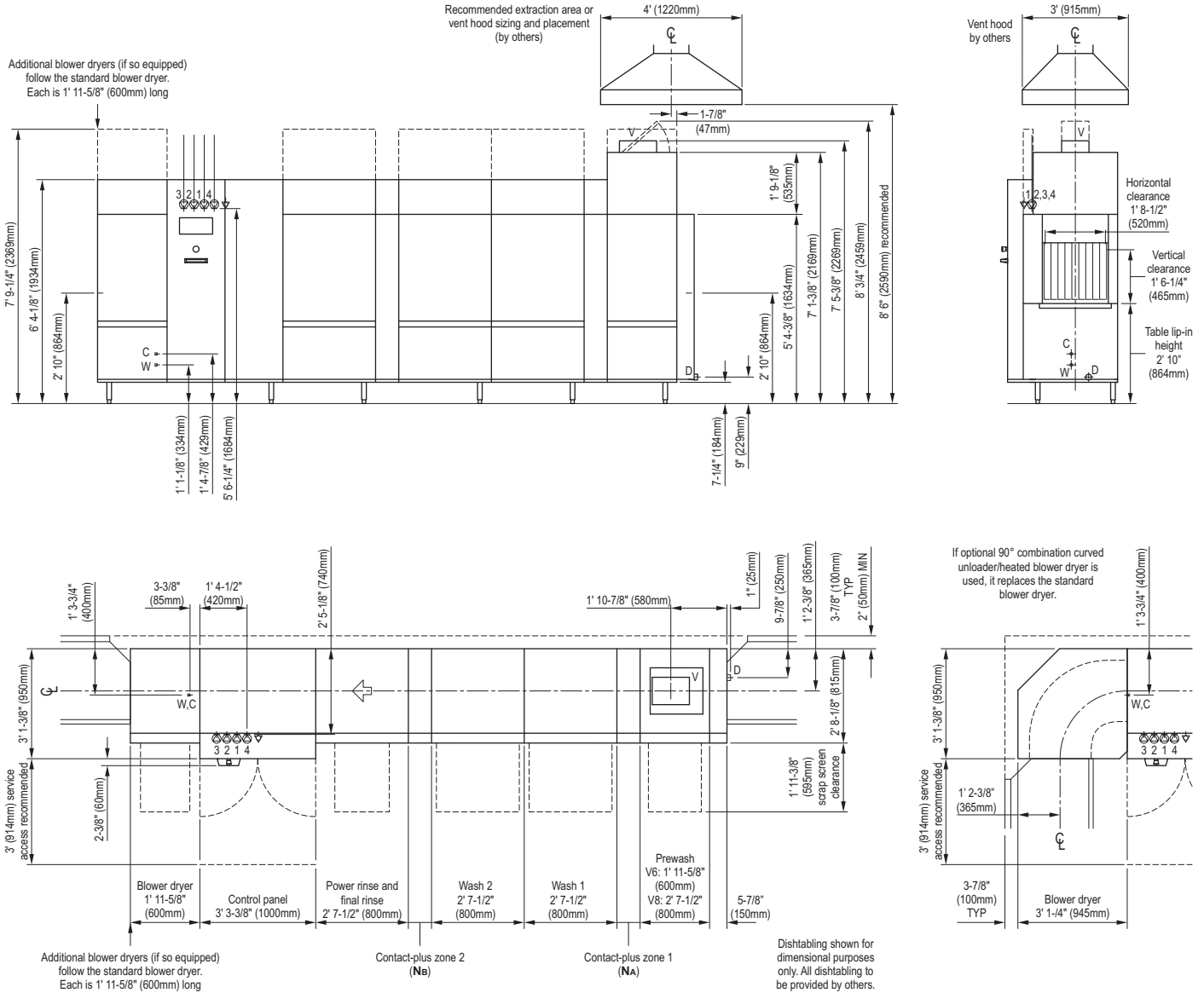

Contact-plus zone 1 (N_A) Contact-plus zone 2 (N_B) Model number code

None	7-7/8" (200mm)	K-L54 V? N02 P8
7-7/8" (200mm)	7-7/8" (200mm)	K-L54 V? N22 P8
11-7/8" (300mm)	11-7/8" (300mm)	K-L54 V? N33 P8
1' 3-3/4" (400mm)	1' 3-3/4" (400mm)	K-L54 V? N44 P8
1' 7-5/8" (500mm)	1' 7-5/8" (500mm)	K-L54 V? N55 P8
1' 11-5/8" (600mm)	1' 11-5/8" (600mm)	K-L54 V? N66 P8
2' 7-1/2" (800mm)	2' 7-1/2" (800mm)	K-L54 V? N88 P8
3' 3-3/8" (1000mm)	3' 3-3/8" (1000mm)	K-L54 V? N1010 P8

NOTE: As ware proceeds through the machine and closer to the final rinse, the water contacting the ware becomes warmer and cleaner. Large items and flat items (particularly sheet pans, trays, totes, etc.) can carry over cooler, soiled water forward in the machine. The contact-plus zone provides a landing area for this water, allowing it to return to the previous tank. This reduces detergent consumption and tank heating energy use.

Wider contact-plus zones also provide a surface that may be used to front-mount detergent or rinse aid systems.

Recommended contact-plus zone configurations:

- For machines washing plates/glasswares - **N02**
- For machines washing a typical ware mix - cafeteria trays and some sheet pans in addition to plates and glasswares - **N22**
- For machines washing containers - **N33** or larger, depending on the size of the container
- For machines with front-mounted detergent and rinse aid dispensers - **N33** or larger, depending on the size of the dispensing systems

Blower dryers

NOTE: All M-iQ rack conveyor warewashers feature at least one heated blower dryer section. One blower dryer provides good results for plates, cutlery and glassware in most cases.

For melamine ware or plastics (trays, insulated items, etc.) a second blower dryer is available, adding 1' 11-5/8" (600mm) to overall machine length.

For some special ware types, additional blower dryer zone(s) beyond the second may provide improved drying results. Consult MEIKO for assistance.

When installing the unit in a corner, a 90° combination curved unloader/heated blower dryer is available as an option. This option may not be combined with additional drying zones.

M-iQ Rack Conveyor - K-L54 Series - Steam heat, left to right

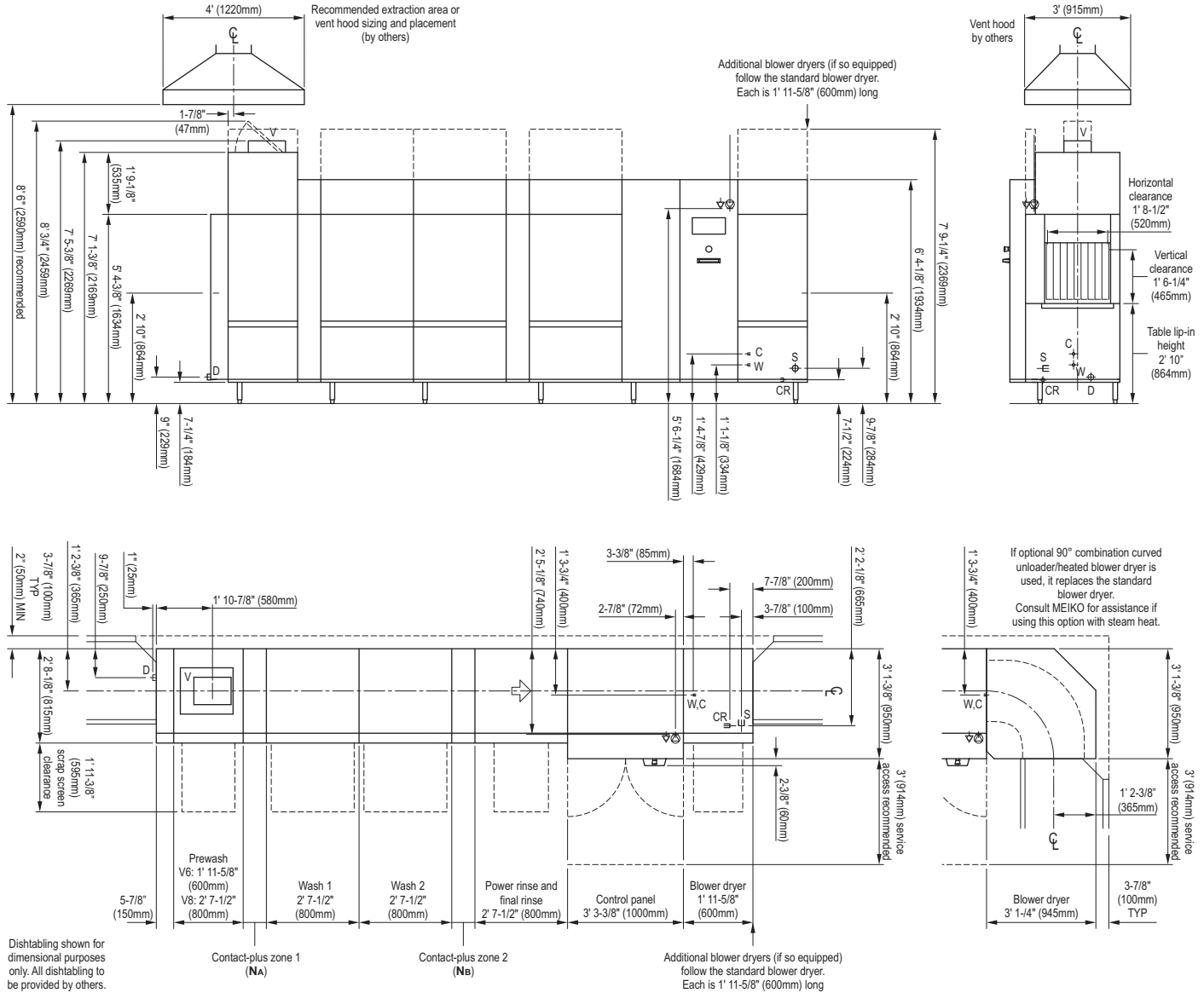

Contact-plus zone 1 (NA) Contact-plus zone 2 (NB) Model number code

None	7-7/8" (200mm)	K-L54 V? N02 P8
7-7/8" (200mm)	7-7/8" (200mm)	K-L54 V? N22 P8
11-7/8" (300mm)	11-7/8" (300mm)	K-L54 V? N33 P8
1' 3-3/4" (400mm)	1' 3-3/4" (400mm)	K-L54 V? N44 P8
1' 7-5/8" (500mm)	1' 7-5/8" (500mm)	K-L54 V? N55 P8
1' 11-5/8" (600mm)	1' 11-5/8" (600mm)	K-L54 V? N66 P8
2' 7-1/2" (800mm)	2' 7-1/2" (800mm)	K-L54 V? N88 P8
3' 3-3/8" (1000mm)	3' 3-3/8" (1000mm)	K-L54 V? N1010 P8

NOTE: As ware proceeds through the machine and closer to the final rinse, the water contacting the ware becomes warmer and cleaner. Large items and flat items (particularly sheet pans, trays, totes, etc.) can carry over cooler, soiled water forward in the machine. The contact-plus zone provides a landing area for this water, allowing it to return to the previous tank. This reduces detergent consumption and tank heating energy use.

Wider contact-plus zones also provide a surface that may be used to front-mount detergent or rinse aid systems.

Recommended contact-plus zone configurations:

- For machines washing plates/glasswares - **N02**
- For machines washing a typical ware mix - cafeteria trays and some sheet pans in addition to plates and glasswares - **N22**
- For machines washing containers - **N33** or larger, depending on the size of the container
- For machines with front-mounted detergent and rinse aid dispensers - **N33** or larger, depending on the size of the dispensing systems

Blower dryers

NOTE: All M-iQ rack conveyor warewashers feature at least one heated blower dryer section. One blower dryer provides good results for plates, cutlery and glassware in most cases.

For melamine ware or plastics (trays, insulated items, etc.) a second blower dryer is available, adding 1' 11-5/8" (600mm) to overall machine length.

For some special ware types, additional blower dryer zone(s) beyond the second may provide improved drying results. Consult MEIKO for assistance.

When installing the unit in a corner, a 90° combination curved unloader/heated blower dryer is available as an option. This option may not be combined with additional drying zones.

M-iQ Rack Conveyor - K-L54 Series - Steam heat, right to left

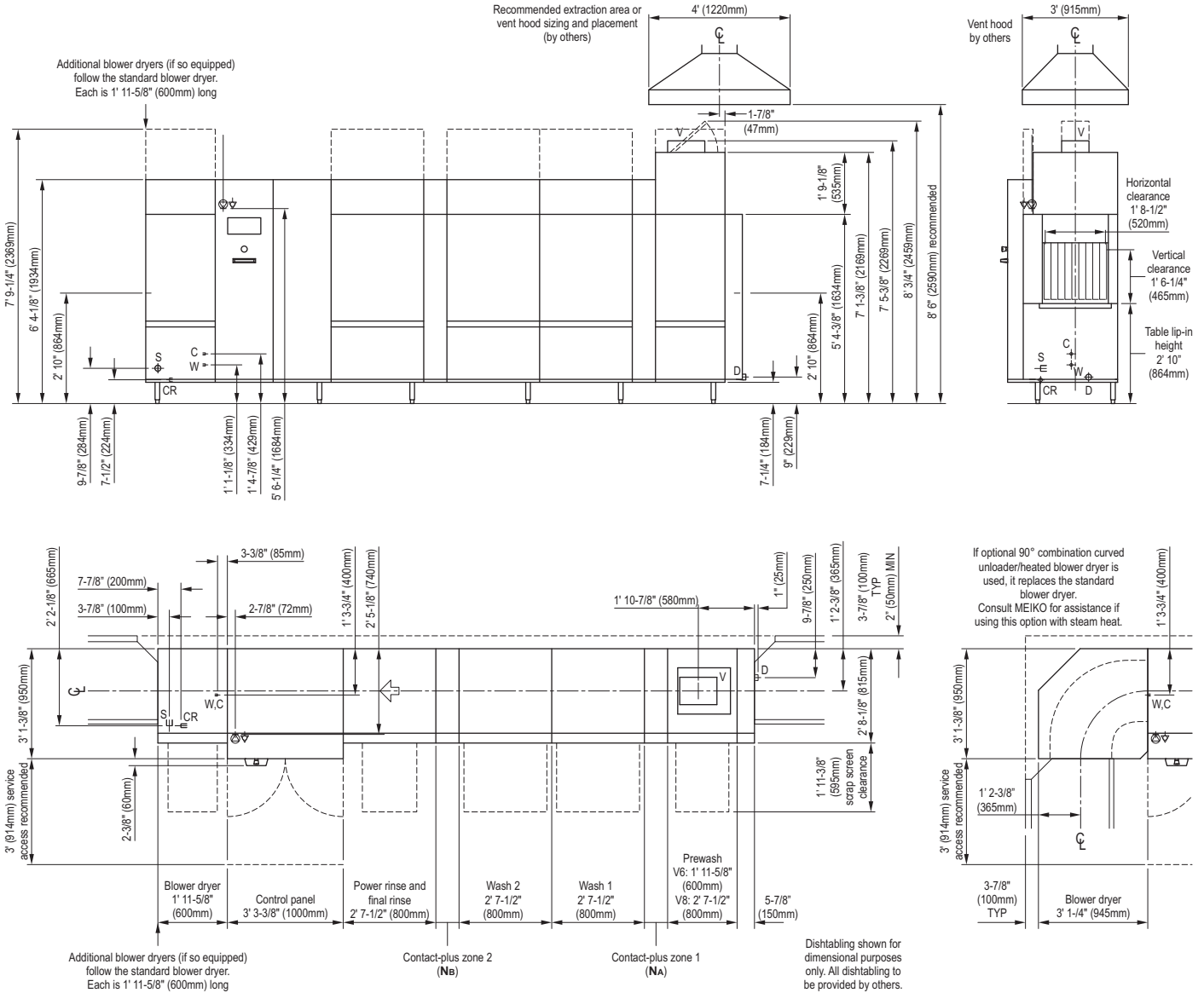

Contact-plus zone 1 (NA)	Contact-plus zone 2 (Nb)	Model number code
None	7-7/8" (200mm)	K-L54 V? N02 P8
7-7/8" (200mm)	7-7/8" (200mm)	K-L54 V? N22 P8
11-7/8" (300mm)	11-7/8" (300mm)	K-L54 V? N33 P8
1' 3-3/4" (400mm)	1' 3-3/4" (400mm)	K-L54 V? N44 P8
1' 7-5/8" (500mm)	1' 7-5/8" (500mm)	K-L54 V? N55 P8
1' 11-5/8" (600mm)	1' 11-5/8" (600mm)	K-L54 V? N66 P8
2' 7-1/2" (800mm)	2' 7-1/2" (800mm)	K-L54 V? N88 P8
3' 3-3/8" (1000mm)	3' 3-3/8" (1000mm)	K-L54 V? N1010 P8

NOTE: As ware proceeds through the machine and closer to the final rinse, the water contacting the ware becomes warmer and cleaner. Large items and flat items (particularly sheet pans, trays, totes, etc.) can carry over cooler, soiled water forward in the machine. The contact-plus zone provides a landing area for this water, allowing it to return to the previous tank. This reduces detergent consumption and tank heating energy use.

Wider contact-plus zones also provide a surface that may be used to front-mount detergent or rinse aid systems.

Recommended contact-plus zone configurations:

- For machines washing plates/glasswares - **N02**
- For machines washing a typical ware mix - cafeteria trays and some sheet pans in addition to plates and glasswares - **N22**
- For machines washing containers - **N33** or larger, depending on the size of the container
- For machines with front-mounted detergent and rinse aid dispensers - **N33** or larger, depending on the size of the dispensing systems

Blower dryers



NOTE: All M-iQ rack conveyor warewashers feature at least one heated blower dryer section. One blower dryer provides good results for plates, cutlery and glassware in most cases.

For melamine ware or plastics (trays, insulated items, etc.) a second blower dryer is available, adding 1' 11-5/8" (600mm) to overall machine length.

For some special ware types, additional blower dryer zone(s) beyond the second may provide improved drying results. Consult MEIKO for assistance.

When installing the unit in a corner, a 90° combination curved unloader/heated blower dryer is available as an option. This option may not be combined with additional drying zones.

M-iQ Rack Conveyor - K-L54 Series - Utility legend

-  Electrical connection(s)
- Electrically-heated machines have four (4) connections. Steam-heated machines have one (1) connection. Incoming leads must be appropriately sized for electrical supply. Individual circuit breaker/disconnects with lockout/tagout strongly recommended (provided by others).
 - Ampacity shown on utility chart, Page 7
-  Equipotential ground connection
- W** Water, warm (initial fill connection)
- Connection 1/2" NPT
 - Temperature 110-140°F (43-60°C). 140°F (60°C) recommended to reduce start-up time
 - Recommended water hardness 1-3 grains per U.S. gal.
 - Initial fill volume on utility chart, Page 7
- C** Water, cold (final rinse connection)
- Connection 1/2" NPT
 - Temperature cold as available. 50°F/10°C recommended to reduce steam emissions
 - Recommended water hardness 1-3 grains per U.S. gal.
 - Final rinse consumption on utility chart, Page 7
- D** Drain connection
- Connection to 2" (50mm) OD horizontal drain outlet (HDPE piping).
 - Indirect routing to 4" (100mm) floor drain recommended. Pipe to be connected to 2" (50mm) OD line (or 1-1/2" pipe) via no-hub. Additional piping to drain to be supplied by others.
- S** Steam connection (steam-heated machines only)
- Connection 1-1/2" NPT
 - Constant steam pressure is REQUIRED (pressure to be specified at time of order). If pressure is below minimum shown, consult factory. If pressure is above maximum shown, use of a regulator is REQUIRED (supplied by others).
 - Pressure ranges (specify at time of order):
 - 7-14 PSI (0.51-1.0 bars)
 - 15-22 PSI (1.1-1.5 bars)
 - 23-29 PSI (1.6-2.0 bars)
 - Consumption on utility chart, Page 7
- CR** Condensate return connection (steam-heated machines only)
- Connection 1" NPT
 - Condensate return line must be pressure-free
- V** Vent connection
- Machine vent is powered, intended for indirect vent connection
 - Extraction area detailed on drawings (pages 2-5) and utility chart (page 7)
 - Exhaust air volume on utility chart (page 7)

M-iQ Rack Conveyor - K-L54 Series - Suggested dishtabling

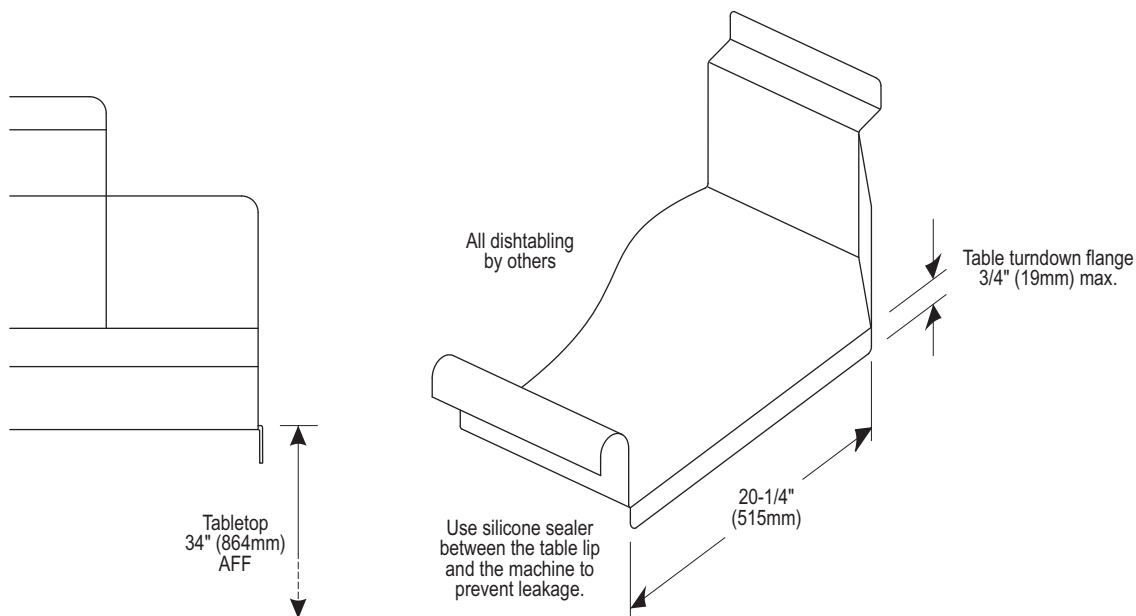

M-iQ Rack Conveyor - K-L54 Series - Technical Specifications

Operating Capacities and Conveyor Specifications (NSF Rated)

Conveyor belt speed (max.)	8.27' (2.52m)/min.
Racks per hour (max)	297.7
Dishes per hour (max.) ¹	7,442
Water consumption/rack (max)	0.15 gal. (0.57 liters)
Water consumption/hr. (max)	44.7 gal. (169.2 liters)
Horizontal clearance	1' 8-1/2" (520mm)
Vertical clearance	1' 6-1/4" (465mm)

¹ Maximum dishes per hour as calculated with NSF formula (maximum racks per hour x 25). This formula assumes full machine utilization regardless of conveyor speed or ware size. Loading under operating conditions will vary. For assistance with ware throughput calculations and machine selection, contact MEIKO at sales@meiko.us.

² Heat load shown is for dishwasher only and does not include heat emitted by ware exiting the machine. Heat emitted by ware is site-specific and outside the scope of this spec sheet. For assistance, contact MEIKO at sales@meiko.us.

Venting Specifications

Machine exhaust	167 CFM (284m ³ /h)
Recommended room air	333 CFM (566m ³ /h)
Recommended total	500 CFM (850m ³ /h)
Recommended extraction area	3' (900mm) W x 4' (1220mm) L

	<i>Sensible</i>	<i>Latent</i>	<i>Total</i>
@ 208V/60Hz/3Ph	21,155 BTU/hr (6.2 kW)	10,578 BTU/hr (3.1 kW)	31,733 BTU/hr (9.3 kW)
Per add'l blwr dryer	+ 1,024 BTU (0.3 kW)	+ 341 BTU (0.1 kW)	+ 1,365 BTU (0.4 kW)
@ 230V/60Hz/3Ph	20,132 BTU/hr (5.9 kW)	9,895 BTU/hr (2.9 kW)	30,027 BTU/hr (8.8 kW)
Per add'l blwr dryer	+ 1,024 BTU (0.3 kW)	+ 682 BTU (0.2 kW)	+ 1,706 BTU (0.5 kW)
@ 460V/60Hz/3Ph	22,179 BTU/hr (6.5 kW)	11,260 BTU/hr (3.3 kW)	33,439 BTU/hr (9.8 kW)
Per add'l blwr dryer	+ 1,365 BTU (0.4 kW)	+ 1,024 BTU (0.3 kW)	+ 2,389 BTU (0.7 kW)

Water and Drain Specifications

Minimum water temperatures:

- Prewash tank No minimum - 110-140°F (43-60°C) typical
- Wash tank 1 150°F (66°C)
- Wash tank 2 150°F (66°C)
- Power rinse 160°F (72°C)
- Final rinse 180°F (82°C)

Incoming water temperatures:

- Initial fill line 110°-140°F (43°-60°C)
- Final rinse line Cold as available, 50°F (10°C) recommended

Incoming water line sizes:

- Initial fill line 1/2" NPT
- Final rinse line 1/2" NPT

	<i>K-L54 V6 N** P8</i>	<i>K-L54 V8 N** P8</i>
Initial fill	78.5 gal. (297.0 liters)	85.4 gal. (323.0 liters)
Consumption at 100% cap.	44.7 gal. (169.2 liters)/hr 0.15 gal. (0.57 liters)/rack	

Recommended water hardness 1-3 grains/gal

Drain specifications:

- Connection (standard) 2" (50mm) OD
- Connection (with no-hub) 1-1/2" pipe
- Recommended floor drain (min.) 4" (100mm)
- Maximum drain flow rate 15 gals. (56.8 liters) per minute

Machine Electrical Specifications

	<i>208 V/60 Hz/3 Ph</i>				<i>230 V/60 Hz/3 Ph</i>				<i>460 V/60 Hz/3 Ph</i>			
	TB1	TB2	TB3	TB4	TB1	TB2	TB3	TB4	TB1	TB2	TB3	TB4
Electric tank heat, K-L54 V6 N** P8	40.15 A	91.51 A	38.18 A	43.90 A	39.75 A	80.70 A	30.32 A	38.00 A	24.73 A	43.50 A	19.40 A	19.80 A
Electric tank heat, K-L54 V8 N** P8	46.25 A	91.51 A	38.18 A	43.90 A	45.85 A	80.70 A	30.32 A	38.00 A	27.88 A	43.50 A	19.40 A	19.80 A
Steam tank heat/elec. blower dryer, K-L54 V6 N** P8	54.11 A	--	--	--	51.59 A	--	--	--	32.01 A	--	--	--
Steam tank heat/steam blower dryer, K-L54 V6 N** P8	45.11 A	--	--	--	44.09 A	--	--	--	27.01 A	--	--	--
Steam tank heat/elec. blower dryer, K-L54 V8 N** P8	63.11 A	--	--	--	59.09 A	--	--	--	37.01 A	--	--	--
Steam tank heat/steam blower dryer, K-L54 V8 N** P8	51.21 A	--	--	--	50.19 A	--	--	--	30.16 A	--	--	--
Per additional elec. blower dryer section (electric machine)	+ 2.25 A	--	+9.00 A	--	+ 2.25 A	--	+ 7.50 A	--	+ 1.30 A	--	+ 5.00 A	--
Per additional elec. blower dryer section (steam machine)	+ 11.25 A	--	--	--	+ 9.75 A	--	--	--	+ 6.30 A	--	--	--
Per additional steam blower dryer section	+ 2.25 A	--	--	--	+ 2.25 A	--	--	--	+ 1.30 A	--	--	--

Component Electrical Specifications

Prewash pump motor, K-L54 V6 N** P8	1.00 hp (0.75 kW)
Prewash pump motor, K-L54 V8 N** P8	3.00 hp (2.20 kW)
Wash pump motor (each)	3.00 hp (2.20 kW)
Power rinse pump motor	1.00 hp (0.75 kW)
Final rinse pump motor	0.75 hp (0.55 kW)
Vent motor	0.17 hp (0.13 kW)
Drive motor	0.16 hp (0.12 kW)
Blower dryer motor (each)	0.67 hp (0.50 kW)
Loading deck flushing pump	0.134 hp (0.10 kW)
M-Filter pump, prewash	0.134 hp (0.10 kW)
M-Filter pump, wash	0.134 hp (0.10 kW)
M-Filter pump, power rinse	0.134 hp (0.10 kW)
Control system, 208V/60Hz/3Ph or 230V/60Hz/3Ph	0.88 kW
Control system, 460V/60Hz/3Ph	3.30 kW

Electric Heating Elements (electrically-heated units only)

	<i>208 V/60 Hz/3 Ph</i>	<i>230 V/60 Hz/3 Ph</i>	<i>460 V/60 Hz/3 Ph</i>
Wash tank 1 heat	10.52 kW	9.09 kW	11.50 kW
Wash tank 2 heat	13.86 kW	12.86 kW	15.40 kW
Power rinse tank heat	19.12 kW	19.29 kW	19.20 kW
Booster heater (max.) ¹	15.80 kW	15.20 kW	15.80 kW
Blower dryer heat (each)	3.20 kW	3.00 kW	4.00 kW

¹ Maximum heater output shown. Incoming cold water is pre-heated by heat captured from machine exhaust air prior to being heated to sanitizing 180°F (82°C) by booster heater. Booster heater incorporates variable output and is automatically regulated to ensure proper final rinse temperature, regardless of incoming water temperature or machine operating status (startup, operation, idle).

Typical booster output at operating temperature: 5.588 kW

Steam Specifications (steam-heated units only)

Steam supply connection	1-1/2" NPT	
Condensate return connection	1" NPT	
Steam supply pressure (must be specified):		
7-14 PSI (0.51-1.0 bars)	15-22 PSI (1.1-1.5 bars)	23-29 PSI (1.6-2.0 bars)

Steam consumption (max.):

- Machine with electric blower dryer 218 lbs/hr (63.13 kW)
- Machine with steam heated blower dryer 229 lbs/hr (66.32 kW)
- Per additional steam blower dryer section + 11 lbs/hr (3.20 kW)

Note: All specifications are subject to change without notice based on MEIKO's dedicated product improvement program.

Equipment Specification: M-iQ K-L54 V ___ N ___ P8 - Item No. _____

Unit will be a:

___ **MEIKO M-iQ K-L54 V6 N ___ P8** multiple tank rack conveyor dishmachine, consisting of a 5-7/8" (150mm) entrance, 1' 11-5/8" (600mm) prewash compartment with 1 hp (0.75 kW) pump motor, two 2' 7-1/2" (800mm) wash compartments, each with 3 hp (2.2 kW) pump motor, contact-plus zone between wash and rinse sections, 2' 7-1/2" (800mm) combination rinse compartment (with 1 hp / 0.75 kW power rinse pump motor and 3/4 hp / 0.55 kW final rinse pump motor), and a 5' 3" (1600mm) combination control panel / heated blower drying zone.

___ **MEIKO M-iQ K-L54 V8 N ___ P8** multiple tank rack conveyor dishmachine, consisting of a 5-7/8" (150mm) entrance, 2' 7-1/2" (800mm) prewash compartment with 3 hp (2.2 kW) pump motor, two 2' 7-1/2" (800mm) wash compartments, each with 3 hp (2.2 kW) pump motor, contact-plus zone between wash and rinse sections, 2' 7-1/2" (800mm) combination rinse compartment (with 1 hp / 0.75 kW power rinse pump motor and 3/4 hp / 0.55 kW final rinse pump motor), and a 5' 3" (1600mm) combination control panel / heated blower drying zone.

Unit will be NSF rated at a maximum conveyor speed of 8.27' (2.52m) per minute (297.7 dishracks per hour). Final rinse water consumption will not exceed a maximum of 44.7 U.S. gal. (169.2 liters)/hour, or 0.15 gal. (0.57 liters)/rack.

Unit will be NSF and ETL listed.

Unit will utilize an internal booster heater to maintain a minimum 180°F (82°C) minimum fresh water sanitizing rinse. Wash tank temperature will be automatically maintained at a minimum temperature of 150°F (66°C). Power rinse tank temperature will be automatically maintained at a minimum temperature of 160°F (72°C).

All tank, final rinse and blower dryer heating will be accomplished by:

___ Electric heaters ___ Steam coil heaters *

* *NOTE: Some steam-heated machine configurations use electrically-heated blower dryers. Consult MEIKO for additional information.*

If steam, specify pressure:

___ 7-14 PSI ___ 15-22 PSI ___ 23-29 PSI
(0.51-1.0 bars) (1.1-1.5 bars) (1.6-2.0 bars)

Operating voltage will be:

___ 208V/60Hz/3Ph ___ 230V/60Hz/3Ph ___ 460V/60 Hz/3 Ph

Direction of operation will be:

___ Left to right ___ Right to left

Unit will be equipped with the following blower dryer system:

___ A single heated blower dryer for complete drying of all dishes, crockery and silverware, with a 0.67 hp blower dryer motor. Drying tunnel will be 1' 11-5/8" (600mm) in length.

___ Dual adjacent heated blower dryers for complete drying of all dishes, crockery and silverware, and improved drying of plastic trays. Each drying tunnel will feature a 0.67 hp blower dryer motor and will be 1' 11-5/8" (600mm) in length.

___ A 90° curved unloader with integral single heated blower dryer for complete drying of all dishes, crockery and silverware, with a 0.67 hp blower dryer motor. Drying tunnel adds 3' 1-1/4" (945mm) to machine length. Due to racks exiting front of machine, blower dryer access door is not present with this configuration.

Unit will feature a glass touch screen control panel and display. Display will provide customized information based on the machine operating mode, including tank and final rinse temperatures and selection of three different operating speeds. Display will provide service diagnostic information, automatic logging of operating history, and the ability for the operator to enter manual log entries for later retrieval.

Unit will feature a single-point drain connection and single-point indirect ventilation connections. Steam-heated machines will feature a single-point electrical connection.

Unit will have the following standard features:

Operating Features

Unit will feature fully automatic operation. Racks pushed into the machine will activate water flow and pump operation. Final rinse activates only when ware is located in the machine to conserve water, chemicals and heating energy. Pumped final rinse provides consistent results and water consumption regardless of variations in supply water pressure. Waste Air Heat Recovery System reclaims waste heat generated by the machine as free energy to preheat the incoming rinse water, reducing energy consumption and allowing hot-water sanitizing from a cold water supply (minimum 50°F / 10°C). Water will be delivered from Waste Air Heat Recovery System exchanger to an internal booster heater to provide the required rise for a minimum 180°F (82°C) sanitizing final rinse. Booster heater will incorporate variable output and will be automatically regulated to ensure optimum performance regardless of incoming water temperature or machine operating status (startup, operation, idle).

Unit will feature fully automatic operation with one-touch selection of three different conveyor speeds. Unit will feature a main control panel on the front of the machine as well as a push-pull emergency stop switch. Main control panel will be a glass touch screen display providing access to temperature displays, machine status, service diagnostics and machine logs as well as operating controls. Display will be capable of displaying information in multiple selectable languages to include English, French, Spanish and German.

Construction Features

Clearance height within the machine will be 1' 6-1/4" (465mm). Rack entrance height will be 2' 10" (864mm) A.F.F., +/- 1/2" (12mm) from adjustable legs, to ensure compatibility with standard dishtabling. Rack drive will pull racks smoothly from either side, rather than using a center-drive configuration, to prevent obstruction of the spray from lower wash and rinse arms.

Unit will feature double-wall, insulated stainless steel construction on front, top and rear panels to retain heat inside the machine, conserve energy and provide a cool-to-the-touch exterior. Prewash, wash and power rinse manifolds will be internally mounted to ensure a cool-to-the-touch rear panel, and will be spaced from rear wall of tank for easier cleaning.

Tank drains will feature magnetic switches to prevent operation if drain plug is not in place. Tank pump motors will be vertically-installed for easier serviceability and self-draining. Motors will include a safety switch to automatically signal the operator if a leaking pump seal is detected.

Wash arms of unit will be mounted in easily-removed assemblies, and will feature concave, slotted nozzles to minimize clogging. All prewash, wash, power rinse and final rinse arms will be of stainless steel construction. Final rinse nozzles to feature individual, screw-in stainless steel orifices for durability and simple cleaning. Front-sloping wash tanks will be of all 304-series stainless steel construction.

Cleaning Features

Prewash, wash and power rinse tanks will each feature a multi-stage filtration system with multiple, nesting scrap screens. Food soil will be collected and sorted by nested scrap screens and flushed into the drain line using a dedicated 0.134 hp M-Filter active filtration pump. Active M-iQ filtration will completely eliminate the need to manually remove and empty scrap baskets during operation. Upon shutdown, unit will use water already inside the machine, as well as a minimal amount of fresh water, for an automatic cleaning mode to reduce the need for manual cleaning. All components of unit that require regular manual cleaning will be marked in a blue accent color for easy identification. Prewash, wash and power rinse arm end caps will be tethered to arms with braided stainless steel wire to prevent loss during cleaning.

Efficiency Features

Unit will feature a single-point vent connection. Heat will be drawn the length of the machine to the load end vent for superior temperature distribution, reduced air emissions and reduced energy consumption. Load end vent will incorporate a MEIKO Waste Air Heat Recovery System heat exchanger to preheat incoming final rinse water and cool exhaust air, permitting final rinse operation using a cold water supply. Unit will employ active soil filtration and removal in each tank to reduce detergent consumption by up to 50%.

Unit will have the following optional features:

- ___ Direct drive sideloader
- ___ 90° curved loader
- ___ 90° curved unloader
- ___ Drain water tempering - reduces drain water below 140°F (60°C)
- ___ Single-point electrical connection (electrically-heated machines only)
- ___ Flanged, bolt-down feet

Unit will include the following doors:

- ___ Spring-loaded lifting doors extending the full width of each applicable section (prewash, wash, rinse, blower dryer). All doors will feature dual-wall, insulated construction, and door safety switches to prevent operation while in the open position.
- ___ Hinged doors extending the full width of each applicable section (prewash, wash, rinse, blower dryer). All doors will feature dual-wall, insulated construction, and door safety switches to prevent operation while in the open position. Tanks and sections 2' (600mm) in length or shorter will feature a single door. Longer tanks and sections will feature dual doors.

Unit will have the following contact-plus zones:

Contact-plus zones between prewash and wash sections (optional) and between wash and rinse sections (standard) minimize cool/soiled water carryover between tanks, which reduces heating energy and detergent consumption.

Between prewash and wash sections (first digit after "N" in model number)

- ___ 0: None (standard) ___ 2: 7-7/8" (200mm) ___ 3: 11-7/8" (300mm)
- ___ 4: 15-3/4" (400mm) ___ 5: 19-5/8" (500mm) ___ 6: 23-5/8" (600mm)
- ___ 8: 31-1/2" (800mm) ___ 10: 39-3/8" (1000mm)

Between wash and rinse sections (second digit after "N" in model number)

- ___ 2: 7-7/8" (200mm, standard) ___ 3: 11-7/8" (300mm)
- ___ 4: 15-3/4" (400mm) ___ 5: 19-5/8" (500mm) ___ 6: 23-5/8" (600mm)
- ___ 8: 31-1/2" (800mm) ___ 10: 39-3/8" (1000mm)